



## Concentric Butterfly Valve

- Model No. GVK-1000Series
- Usable of bi-directional flow with tight shut-off at full rating pressure.
- Wafer, Lug and Double Flange Type





# Concentric Butterfly Valve

## [Model No. : GVK-1000Series]

### • Standard Compliance

- International Standard API609, JIS F7480, KSV7490, ISO5752, JIS B2032, BS5155, DIN2501.

### • Production Range (Other dimensions on request)

- Size : Wafer DN50 ~ DN500

Lug DN50 ~ DN800

Flange DN50 ~ DN1200 (other Dimensions on request)

- Rating Pressure : Up to 16Barg

- Rating Temperature : -25°C ~ 120°C

### • Applicable Flange Standard

- KS/JIS 5K, 10K, 16K

- ASME B16.1 Class 125LB

- ASME B16.5 Class 150LB

- ISO 7005 PN6, PN10, PN16

- EN 1092 PN6, PN10, PN16

- GB 2501/2506 PN6, PN10, PN16

- DIN 2501 PN6, PN10, PN16

### • Operations

- Manual Lever, Worm gear operation

- Single & Double Acting Pneumatic Actuator operation

- Electric Motor Actuator operation

- Hydraulic Actuator & Manual Hydraulic Actuator operation

### • Material

Body Cast Iron / Ductile Iron

Cast Steel

Stainless steel

Al-bronze

Disc Stainless steel

Al-bronze

Seat Rubber - NBR, EPDM, VITON

Stem Stainless steel

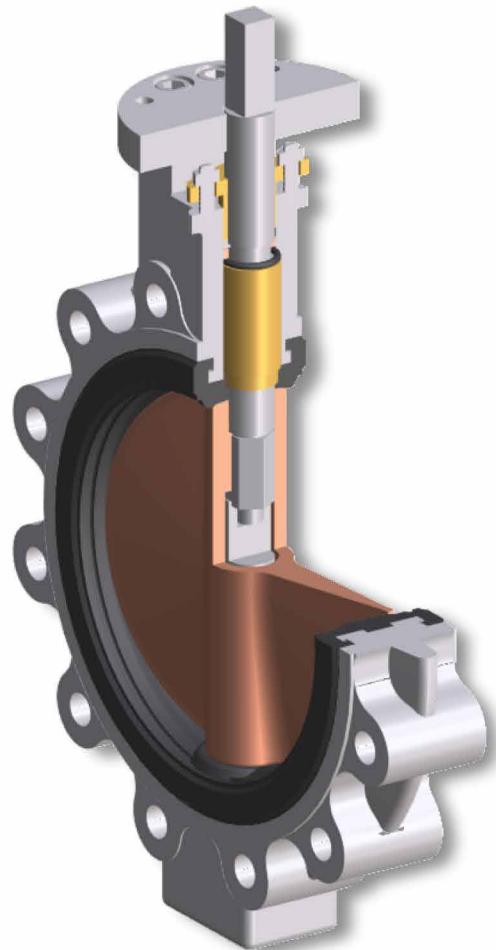

# DESIGN FEATURE

## • Complete dry shaft sealing design.

- Multi seal design keeps the sealing in way of valve stem perfectly without additional tightening device after operating of the valve.

- The sealing design on the connection part of stem, disc and seat which is improved construction

- ① Disc(top&down side) & seat sealing shows perfect sealing effect with connection with the sphere shape.
- ② Even if the disc part leaked by the fluid pressure to keep the position by the seat & stem sealing part will be remained without deformation for sealing.
- ③ O-ring part exists in the valve independently of the seat to prevent leakage.

- If leaking on multi seal design in case, leakage will not occurred by tightening packing gland bolt.(Bottom cover)

Because the seat connected to the stem bearings are better sealed by packing gland bolt(& bottom cover) tightening pressure and have a complete sealing structure.

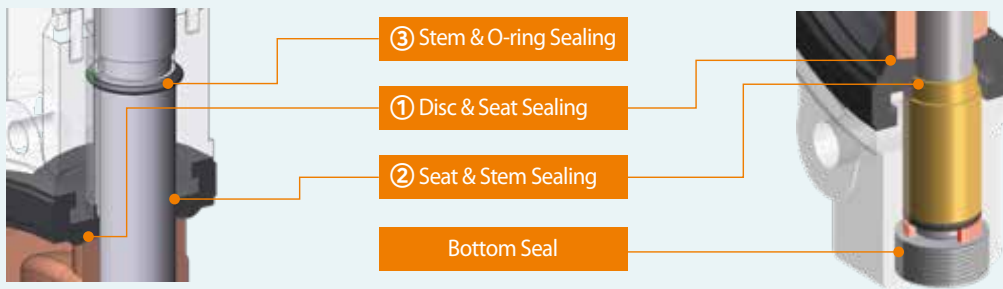
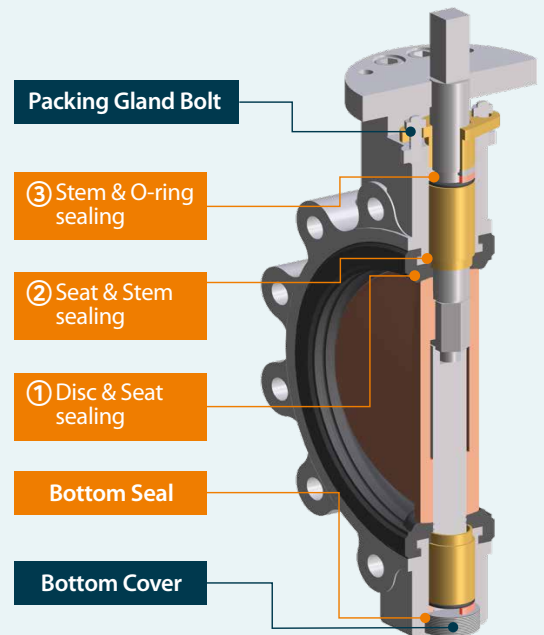

- Dry Shaft Design -

## • Seat Design



- GV Korea's Concentric butterfly valve have a superb structure in the seat.

- The central part of the seat top&down is same spherical shape as disc so that the seat can contact the disc smoothly.

- The disc in contact with the spherical seat operates at low torque.

- The seat inner groove prevents deformation of the seat by piping tightening pressure.

Also, it's possible to reduce the torque increased on the valve seat when the piping tightening pressure.

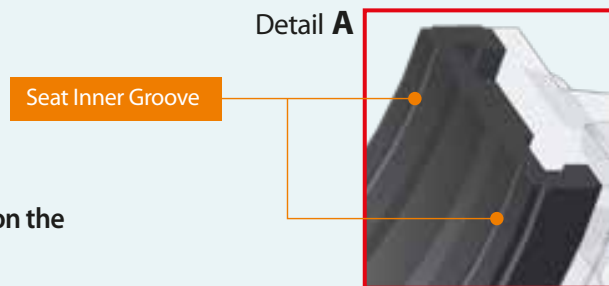

## • Disc Design

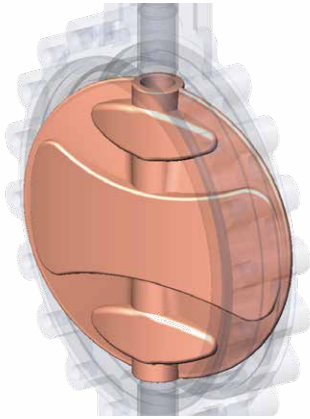

- Disc is designed as special structure which maintains a sufficient intensity under high-pressure and high velocity.
- The disc is produced by full spherical machining.
- Every part of the sealing surface is spherical as the seat surface.
- These fit together with a smooth touch and torque are reduced.
- Specially, the disc design of above DN400 is shaped to suit fluid flow as shown in the figure and prevents turbulence.

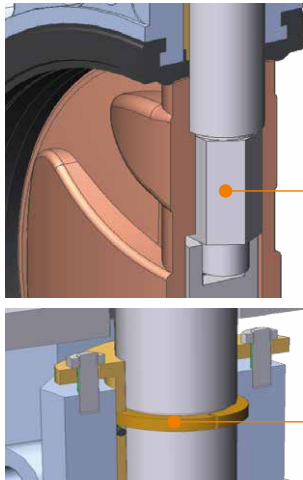
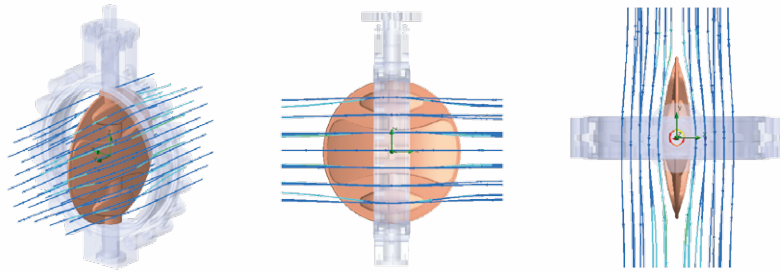

## • Pinless type Stem Design (Hexagon type stem)

- Pinless type stem(Hexagon type stem) to be provided to fix disc into the stem, instead of thread bolt & taper type pin to avoid unexpected releasing thread of the caused by the environmental vibration and disc pin corrosion.
- It is easy to disassemble and assemble after installation, and is fully compatible without additional processing when supplying spare parts.

Pinless type stem  
(Hexagon stem)

Anti blow-out Ring

## • Blow-Out Proof Stem

The antiblow ring is installed between the machinical stem groove and gland ring.

## • Adjustable Stem Packing.

- The O-rings and seats connected to the stem bearings are better sealing through gland bolting pressure even after the valve is installed on the pipe.
- The stem packing design features easy access to adjusting hex head nuts without special tool.
- When tighten the hex head nuts, be careful not to be overtightened.

Top flange

Adjustable stem packing.

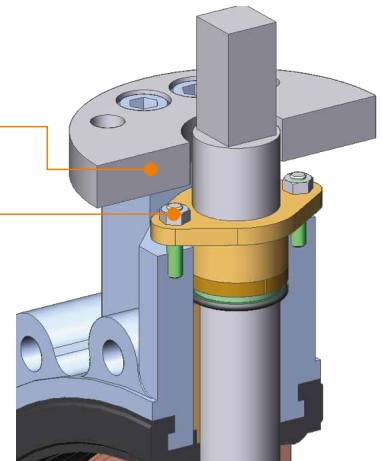

## • Top Flange For Actuator Mount (ISO 5211 Standard)

- The top flange of Butterfly valve is most important parts for mounting of actuator. We provides top flange in accordance with International Standard ISO 5211 and easy modification works can be available for actuator without special tool.



# Storage & Installation

## ○ Storage

1. Be careful not to scratch disc and seat damage.
2. To protect the seat, do not unpack valve until your ready install the valves.  
The valve remains unpacked for a long period of time, dust or other particles may enter the valve and cause seat damage.
3. For long term storage, It is recommended to keep the valves in cool and well-ventilated location.  
Also, It is recommended to keep and carry the valve under the condition of about 15°C in general.
4. In long-term storage valve, must check the operation once a month.

## ○ Installing Valve.

1. Valves can be installed in any position.
2. Before installing the valve, the pipeline & valve must be cleaned from dirt & welding residues.(Otherwise, Valve seat & disc may be damaged.)
3. When installing a butterfly valve directly to other valve or pump unit, install an extension or spacer to prevent the valve disc from contacting the other valve or pump unit.
4. Make sure that there is no warpage in the flange, misalignment, or damage to the mating surface of the flange.
5. Be sure to properly align the valve & mounting flanges.
6. Actuator mounting in downward is not recommended. (Especially for valve size of DN400 or large.)
7. After centering the pipes, insert bolts at the proper locations so that the bottom of the valve can rest upon them to prevent the valve from falling through.
8. Before tightening the installation bolts, make sure that the disc of the valve dose not contact any portion of the flange when valve is fully opened.
9. The installation bolts should be tightened evenly and in the proper sequence.  
Tighten one bolts a small amount, and then proceed to another bolt that is located on the other side.
10. Valve to check proper operation.

## ○ CAUTION

1. Do not weld the piping arounding the valve area under the condition that the valve installed.
2. The pipeline(or equipment unit) must be free tention & electric current.
3. Forcing the valve between the pipe flanges may cause the seat ring to peel off and cause a leak.



**Head Office of GV Korea Co.,Ltd**



**Tianjin Galaxy Co.,Ltd**



**GV Korea Co., Ltd.**

<http://www.gvkorea.co.kr>

📍 50, Yutongdanji 1-ro, Gangseo-gu, Busan, Republic of Korea

✉ [cgl0518@gvkorea.co.kr](mailto:cgl0518@gvkorea.co.kr), [jhk0518@gvkorea.co.kr](mailto:jhk0518@gvkorea.co.kr)

☎ +82-10-5181-2362, +82-10-3850-4529

**Tianjin Galaxy Valve Co., Ltd.**

<http://www.galaxyvalves.com>

📍 No.15 Tianhua Road, Balitai Industrial Area,  
Jinnan District, 300350 Tianjin, P.R.China